

# National Crane Series 900H

## Product Guide



### Features

- 24,5 t (27 USt) rating
- 32 m (105 ft) four-section boom
- Multi-position Easy Reach control panel
- Graphical LMI

# Features

## Graphical LMI

The Graphical Load Moment Indicator (LMI) is standard on all Series 900H machines. The LMI system displays all crane load lifting values simultaneously while providing real-time information about the crane and truck operating system and includes work area definition system (WADS) and operating limits. The LMI is also weatherproof and visible in full or low light.



## "HO"-style outriggers

Two sets of "HO"- style outriggers with 6,09 m (20 ft) full span, 4,27 m (14 ft) mid span setting with manual locks and fully retracted outrigger spread. Main outriggers are equipped with removable ball and socket aluminum foot pads.

## Options to get the job done

- An auger attachment is available on the 28,9 m (95 ft) boom reaching a max digging radius of 11,8 m (39 ft) with full outrigger span
- Personnel basket options are available to allow versatility in operating conditions



## Easy Reach controls

The Easy Reach control station can be tilted to the right or left side of the crane as needed and can be stowed in the center position for transport. The single axis pilot operated crane controls allow smooth operation for each crane function.



# Features

## Performance you can rely on

- Bearings on the boom and retract cables can be greased through access holes in the boom side plates
- Number of internal boom parts has been reduced, decreasing service time when rebuilding the machine
- Internal anti-two-block wire routing eliminates damage potential
- Painting crane components before assembly reduces the possibility of rust, improves serviceability and enhances the appearance of the machine
- State of the art control valve provides smoother operation. The new design eliminates parts, reducing repair costs and improving the machines serviceability
- Speedy-reeve boom tip and sheave blocks simplify rigging changes by decreasing the time needed to change line reeving

- The Series 900H is standard with 410° non-continuous rotation
- Two-speed hoist provides faster winch payout and pickup of unloaded cable
- The stronger standard torsion box improves rigidity, reduces truck frame flex and reduces the need for counterweight
- A control knob located on the swing motor brake release valve can be easily adjusted to the crane operator's swing speed preference
- Easy Glide boom wear pads reduce the conditions that cause boom chatter and vibration. The net result is smoother crane operation



\*Product may be shown with optional equipment.

# Contents

Mounting configurations	5
Specifications	6
Capacities	8
Dimensions	10
Accessories	11

# Mounting configuration

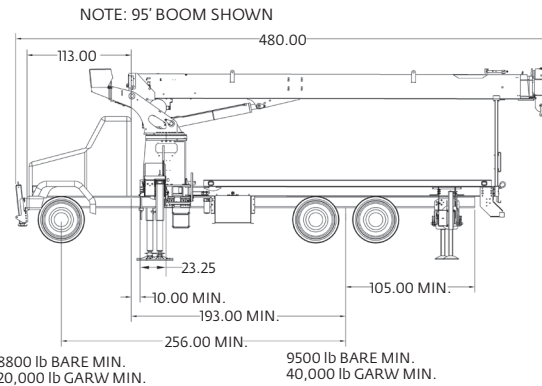
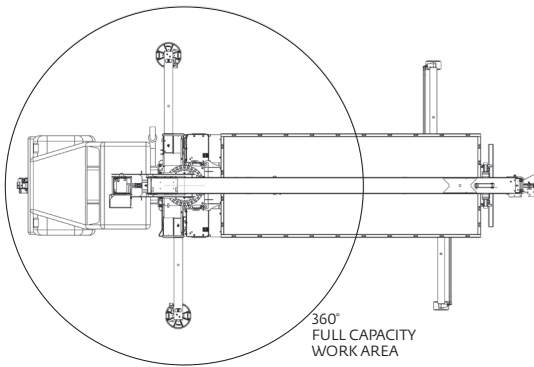

The mounting configuration is based on an 85% stability factor. If the bare truck weight requirements are not met, counterweight will be required. The complete unit must be installed on the truck in accordance with factory requirements. Since individual truck chassis vary, a test must be performed on the unit to verify actual stability after mounting and counterweighting (if required). A summary of mounting and truck requirements are:

#### For 180 degree working area –

- Gross Axle Weight Rating Front (GAWR) – 9072 kg (20,000 lb)
- Gross Axle Weight Rating Rear (GAWR) – 18 144 kg (40,000 lb)
- Gross Vehicle Weight Rating (GVW) – 27 216 kg (60,000 lb)
- Wheelbase (WB) – 6,50 m (256 in)
- Cab to Axle Trunnion (CT) – 4,90 m (193 in)
- After Frame (AF) – 2,67 m (105 in) min.
- Frame Section Modulus (SM) from outrigger to RSOD – 327cm<sup>3</sup> (20 in<sup>3</sup>) and 759 MPa (110,000 psi) material
- Bare chassis weight required for stability prior to installation
  - Front – 3992 kg (8880 lb)
  - Rear – 4309 kg (9500 lb)

#### For 360 degree working area –

- Optional Single Front Stabilizer (SFO)
- Gross Axle Weight Rating Front (GAWR) – 9072 kg (20,000 lb)
- Gross Axle Weight Rating Rear (GAWR) – 18 144 kg (40,000 lb)
- Gross Vehicle Weight Rating (GVW) – 27 216 kg (60,000 lb)
- Wheelbase (WB) – 6,50 m (256 in)
- Cab to Axle Trunnion (CT) – 4,90 m (193 in)
- After Frame (AF) – 2,67 m (105 in) min.
- Frame Section Modulus (SM) from front spring hanger to end of after frame – 327cm<sup>3</sup> (20 in<sup>3</sup>) and 759 MPa (110,000 psi) material
- Bare chassis weight required for stability prior to installation
  - Front – 3992 kg (8800 lb)
  - Rear – 4309 kg (9500 lb)

**Note:** Chassis will require extended front frame rails for SFO addition.

For 360° stability the truck frame must have a 327 cm<sup>3</sup> (20.0 in<sup>3</sup>) section modulus [248,566 N.m (2,200,000 in-lb) RBM] minimum under the crane frame, 245 cm<sup>3</sup> (15 in<sup>3</sup>) section modulus [186,424 N.m (1,650,000 in-lb) RBM] at the front spring rear hanger, 163 cm<sup>3</sup> (10 in<sup>3</sup>) section modulus [124,283 N.m (1,100,000 in-lb) RBM] through the front spring and 49 cm<sup>3</sup> (3 in<sup>3</sup>) section modulus [37,284 N.m (330,000 in-lb) RBM] at the stabilizer attachment point on each truck frame rail.

**NOTE 1:** Gross Vehicle Weight Rating (GVWR) is dependent on all components of the vehicle (axles, tires, springs, fame, etc.) meeting manufacturers' recommendations; always specify GVWR when purchasing trucks.

**NOTE 2:** Diesel engines require a variable speed governor and energize-to-run fuel solenoid for smooth crane operation; electronic fuel injection is required.

**NOTE 3:** All mounting data is based on a National Crane Series 900H with subbase and an 85% stability factor.

**NOTE 4:** The complete unit must be installed in accordance with factory requirements, and a test performed to determine actual stability and counterweight requirements; contact the factory for details.

**NOTE 5:** Transmission neutral safety interlock switch is required. Truck transmission must be capable of having a neutral safety switch added.



# Specifications

## Boom and jib combinations data

Available in two basic models.

**Model 995H** — Equipped with a 8,99 m – 29,0 m (29.5 ft – 95 ft) four-section boom. This model can be equipped with a 7,62 m – 13,41 m (25 ft – 44 ft) two section jib. Maximum tip height with 13,41 m (44 ft) jib is 44,63 m (148 ft).

8,83 m – 29,0 m (29 ft – 95 ft) four-section boom.

**9FJ44M** 7,62 m – 13,41 m (25 ft – 44 ft) two-section jib



**Model 9105H** — Equipped with a 9,69 m – 32,0 m (32 ft – 105 ft) four-section boom. This model can be equipped with a 7,62 m – 13,41 m (25 ft – 44 ft) two-section jib. Maximum tip height with 13,41 m (44 ft) jib is 49,68 m (158 ft).

10,05 m – 32,0 m (33 ft – 105 ft) four-section boom.

**9FJ44M** 7,62 m – 13,41 m (25 ft – 44 ft) two-section jib



**Note:** Maximum tip height is measured with outriggers/stabilizers fully extended.

# Specifications

## 900H winch data

### NOTICE

- Do not deadhead line block against boom tip when extending boom
- Keep at least 3 wraps of loadline on drum at all times
- Use only 9/16 in diameter rotation resistant cable with 38,500 lb breaking strength on this machine
- Maximum capacity with high speed winch is 3000 lb

1 part line    2 part line    3 part line    4 part line    5 part line    6 part line    7 part line

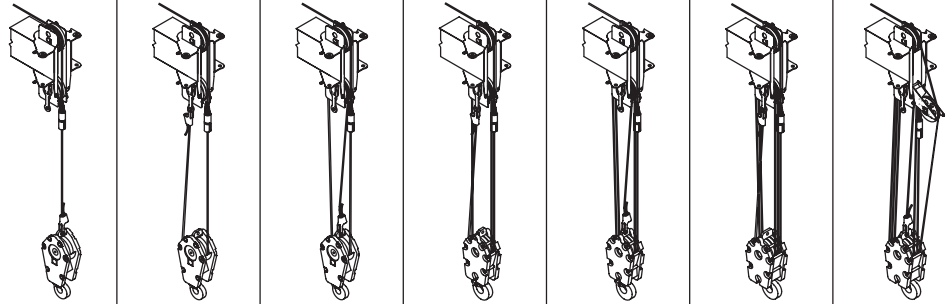

Maximum Boom Length at Maximum Elevation with Rigging Shown with Load Block at Ground Level			95 ft boom 145 ft Boom and jib	95 ft	82 ft	69 ft	56 ft	43 ft	29 ft
			105 ft boom 154 ft Boom and jib	105 ft	76 ft	61 ft	46 ft	46 ft	32 ft
Winch	Cable supplied	Average breaking strength	Lift and speed	Lift and speed	Lift and speed	Lift and speed	Lift and speed	Lift and speed	Lift and speed
Low speed winch	9/16 in diameter rotation resistant	38,500 lb	7700 lb 160 fpm	15,400 lb 80 fpm	23,100 lb 53 fpm	30,800 lb 40 fpm	38,500 lb 32 fpm	46,200 lb 27 fpm	54,000 lb 23 fpm
High speed winch	9/16 in diameter rotation resistant	38,500 lb	3000 lb 310+ fpm	6000 lb 155 fpm	9000 lb 103 fpm	12,000 lb 78 fpm	15,000 lb 62 fpm	18,000 lb 52 fpm	21,000 lb 44 fpm

All winch pulls and speeds are shown on the fourth layer. Winch line pulls would increase on the first, second and third layers. Winch line speed would decrease on the first, second and third layers. Winch line pulls may be limited by the winch capacity or the ANSI 5 to 1 cable safety factor. These are shown below:

**Winch**  
Standard planetary

**4th layer drum pull**  
7700 lb (low speed)  
(3000 lb "burst of speed")

**Allowable cable pull**  
7700 lb

5 t	Downhaul weight	150 lb
12 t	1 sheave block	270 lb
19 t	2 sheave block	350 lb
30 t	3 sheave block	575 lb

# Capacities

## Series 995H: 95 ft boom with 25 ft – 44 ft jib, full span outrigger and stabilizer

National Crane will send you a chart on request – or you may secure needed load rating information through your nearest National Crane dealer.

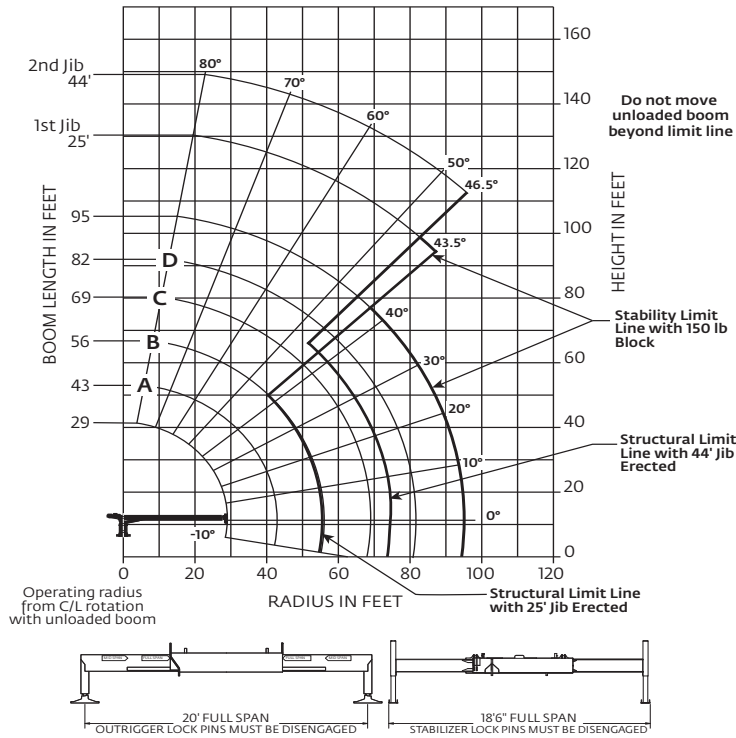

### CAUTION:

- Do not operate crane booms, jib extensions, any accessories or loads within 3 m (10 ft) of live power lines or other conductors of electricity.
- Jib and boom capacities shown are maximum for each section.
- Do not exceed capacities at reduced radii.
- Load ratings shown on the load rating charts are maximum allowable loads with the outriggers properly extended on a firm, level surface and the crane leveled and mounted on a factory recommended truck.
- Always level the crane with the level indicator located on the crane.
- The operator must reduce load to allow for factors such as wind, ground conditions, operating speeds and their effects on freely suspended loads.
- Overloading this crane may cause structural collapse or instability.
- Weights on any accessories attached to the boom or loadline must be deducted from the load chart capacities.
- Do not exceed jib capabilities at any reduced boom lengths.
- Do not deadhead lineblock against boom tip when extending boom or winching up.
- Keep at least three wraps of loadline on drum at all times.
- Use only specified cable with this machine.

### Load chart

#### 29 ft – 95 ft BOOM RATED LOADS WITHOUT JIB

LOADED RADIUS (ft)	LOADED BOOM ANGLE (deg)	29 ft BOOM (lb)	LOADED BOOM ANGLE (deg)	A 43 ft BOOM (lb)	LOADED BOOM ANGLE (deg)	B 56 ft BOOM (lb)	LOADED BOOM ANGLE (deg)	C 69 ft BOOM (lb)	LOADED BOOM ANGLE (deg)	D 82 ft BOOM (lb)	LOADED BOOM ANGLE (deg)	95 ft BOOM (lb)
5	75.8	54,000										
8	69.5	42,000	76.7	29,000								
10	65.1	35,500	73.9	27,000								
12	60.6	31,750	71	25,000	75.9	28,000						
14	55.9	25,500	68.1	23,000	73.8	24,000	77.6	22,000				
16	50.8	23,000	65.2	21,000	71.6	22,000	75.8	18,000				
20	39.3	17,500	59	17,500	67.1	18,000	72.4	17,000	76.2	16,500		
25	17.4	13,000	50.7	13,250	61.3	13,500	67.9	13,000	72.5	13,250	75.9	12,000
30			41.1	10,500	55.2	10,500	63.2	10,250	68.6	10,500	72.7	10,500
35			29.1	8250	48.5	8500	58.2	8250	64.6	8250	69.3	8500
40					41.7	7000	53.5	6750	60.8	6750	66.2	7000
45					32.9	5750	47.9	5500	56.5	5500	62.6	5750
50					21.2	4750	41.9	4900	52.1	4700	58.9	4750
55							34.9	4000	47.3	4100	55.1	4000
60							26.2	3250	42.1	3400	51.2	3300
65							12.9	2700	36.2	2750	46.9	2750
70									29.4	2300	42.4	2350
75									20.4	1800	37.4	1900
80											31.7	1500
85											24.8	1200
90											14.8	900
95												600
0		9000	0	5500	0	3650	0	2300	0	1300	0	600

#### 25 ft – 44 ft JIB RATED LOADS

LOADED RADIUS (ft)	LOADED BOOM ANGLE (deg)	25 ft JIB (lb)	LOADED BOOM ANGLE (deg)	44 ft JIB (lb)
25	79	4900		
30	76.9	4750		
35	74.7	4500	77	2500
40	72.4	4000	75.2	2500
45	69.9	3500	73.4	2500
50	67.6	3500	71.5	2500
55	65	3000	69.7	2200
60	62.4	2750	67.5	2100
65	59.7	2500	65.4	2000
70	56.7	2000	63.2	1850
75	53.6	1600	61	1800
80	50.4	1200	58.4	1750
85	47	850	55.6	1400
90	43.5	600	52.7	1100
95			49.8	850
100			46.5	500

#### RATED LOAD REDUCTIONS WITH STOWED JIB

BOOM LENGTH (ft)	25 ft – 44 ft JIB STOWED
29	Reduce load 800 lb
43	Reduce load 600 lb
56	Reduce load 450 lb
69	Reduce load 350 lb
82	Reduce load 300 lb
95	Reduce load 250 lb

### Note:

- All capacities are in pounds, angles in degrees and radii in feet.
- Loaded boom angles are given as reference only.
- Shaded areas are structurally limited capacities.
- Handling of personnel is only permitted with full span extension of all outrigger and stabilizer beams.

THIS CHART IS ONLY A GUIDE AND SHOULD NOT BE USED TO OPERATE THE CRANE.

The individual crane's load chart, operating instructions and other instructional plates must be read and understood prior to operating the crane.



# Capacities

## Series 9105H: 105 ft boom with 25 ft – 44 ft jib, full span outrigger and stabilizer

National Crane will send you a chart on request – or you may secure needed load rating information through your nearest National Crane dealer.

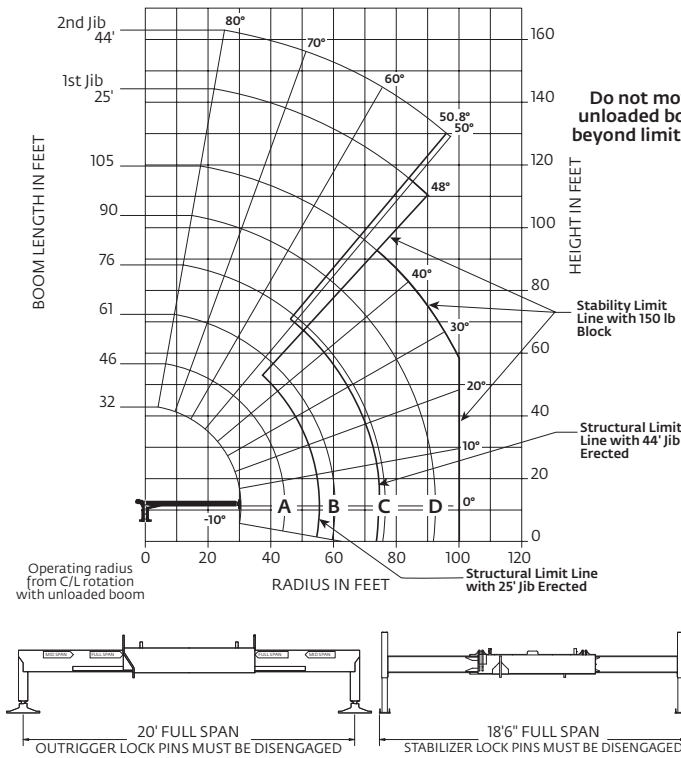

### CAUTION:

- Do not operate crane booms, jib extensions, any accessories or loads within 3 m (10 ft) of live power lines or other conductors of electricity.
- Jib and boom capacities shown are maximum for each section.
- Do not exceed capacities at reduced radii.
- Load ratings shown on the load rating charts are maximum allowable loads with the outriggers properly extended on a firm, level surface and the crane leveled and mounted on a factory recommended truck.
- Always level the crane with the level indicator located on the crane.
- The operator must reduce load to allow for factors such as wind, ground conditions, operating speeds and their effects on freely suspended loads.
- Overloading this crane may cause structural collapse or instability.
- Weights on any accessories attached to the boom or loadline must be deducted from the load chart capacities.
- Do not exceed jib capabilities at any reduced boom lengths.
- Do not deadhead lineblock against boom tip when extending boom or winching up.
- Keep at least three wraps of loadline on drum at all times.
- Use only specified cable with this machine.

### Load chart

#### 32 ft – 105 ft BOOM RATED LOADS WITHOUT JIB

LOADED RADIUS (ft)	LOADED BOOM ANGLE (deg)	32 ft BOOM (lb)	LOADED BOOM ANGLE (deg)	A 46 ft BOOM (lb)	LOADED BOOM ANGLE (deg)	B 61 ft BOOM (lb)	LOADED BOOM ANGLE (deg)	C 76 ft BOOM (lb)	LOADED BOOM ANGLE (deg)	D 90 ft BOOM (lb)	LOADED BOOM ANGLE (deg)	105 ft BOOM (lb)
5	77.2	54,000										
8	71.5	40,000	77.6	29,000								
10	67.6	34,000	75	27,000								
12	63.5	30,000	72.4	24,950	77.4	24,000						
14	59.4	24,000	69.7	22,850	75.4	22,000	78.6	19,000				
16	55	22,000	67	20,450	73.5	20,000	77.1	17,000				
20	45.4	16,500	61.3	16,950	69.4	16,000	73.9	14,500	77.5	13,000		
25	30.2	12,000	53.8	12,900	64.2	13,000	69.9	12,000	74.3	11,000	77.5	10,000
30			45.4	10,000	58.7	10,000	65.7	9,500	70.8	8,750	74.7	9,000
35			35.5	7,750	52.9	8,000	61.4	8,000	67.6	7,500	72.1	8,500
40			23.3	6,300	47.1	6,650	57.3	6,750	64	6,500	69.2	7,100
45					39.8	5,300	52.6	5,500	60.3	5,500	66.1	5,800
50						31.5	4,300	47.5	4,550	56.4	4,450	4,850
55						20.3	3,500	42	3,700	52.3	3,850	3,950
60								35.7	2,950	47.9	3,100	3,200
65								28.3	2,300	43.2	2,500	2,600
70								18.3	1,800	38	2,000	2,100
75										32.2	1,600	1,650
80										25	1,200	1,300
85										14.8	850	950
90											30.1	650
	0	8000	0	4500	0	2500	0	1300	0	500		

#### 25 ft – 44 ft JIB RATED LOADS

LOADED RADIUS (ft)	LOADED BOOM ANGLE (deg)	25 ft JIB (lb)	LOADED BOOM ANGLE (deg)	44 ft JIB (lb)
40	73.9	4400		
45	71.9	4400	74.7	2800
50	69.6	4100	72.9	2700
55	67.2	3600	71.1	2650
60	64.5	2850	69.2	2500
65	61.7	2250	67.1	2300
70	58.9	1750	65.1	2200
75	56	1300	62.8	1950
80	53.1	900	60.2	1550
85	50	550	57.5	1150
90			54.8	850
95			52	550

#### RATED LOAD REDUCTIONS WITH STOWED JIB

BOOM LENGTH (ft)	25 ft – 44 ft JIB STOWED
32	Reduce load 800 lb
46	Reduce load 600 lb
61	Reduce load 450 lb
76	Reduce load 350 lb
90	Reduce load 300 lb
105	Reduce load 250 lb

### Note:

- All capacities are in pounds, angles in degrees and radii in feet.
- Loaded boom angles are given as reference only.
- Shaded areas are structurally limited capacities.
- Handling of personnel is only permitted with full span extension of all outrigger and stabilizer beams.

THIS CHART IS ONLY A GUIDE AND SHOULD NOT BE USED TO OPERATE THE CRANE.

# Dimensions

Weight and centers of gravity include boom, winch, rope, turret, lift cylinder, frame, controls, outriggers, platforms, torque box, boom rest, bumper, downhaul weight.

	G	H	Weight
995H	2423 mm (95.4 in)	1504 mm (59.2 in)	9232 kg (20,352 lb)
9105H	2654 mm (104.9 in)	1539 mm (60.6 in)	9566 kg (21,090 lb)

Above weights and centers of gravity do not include reservoir, RSOD, jib, PTO, pump, bed, SFO.

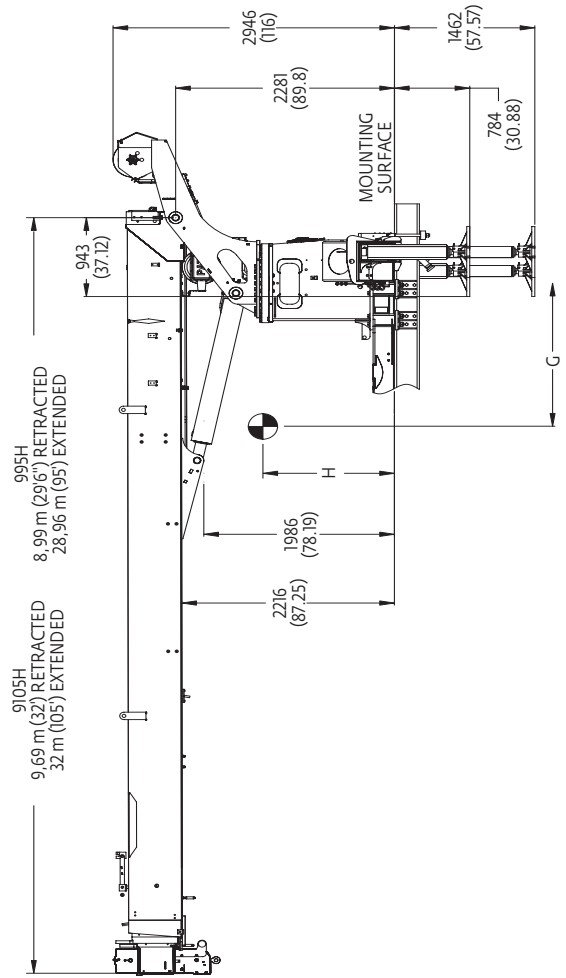
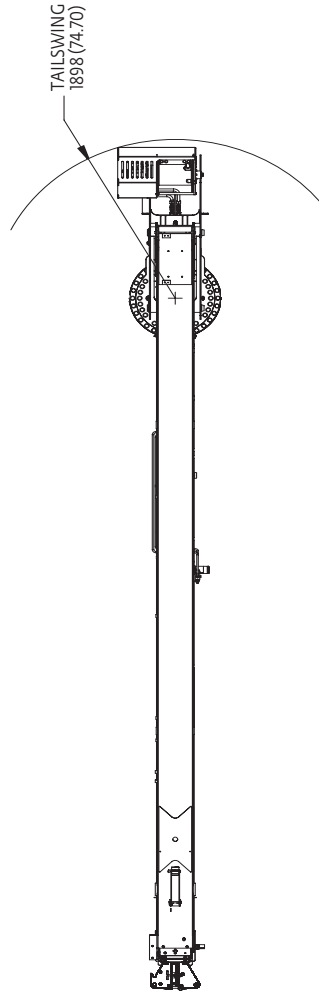

**NOTE: All dimensions are in mm (in) unless otherwise specified**

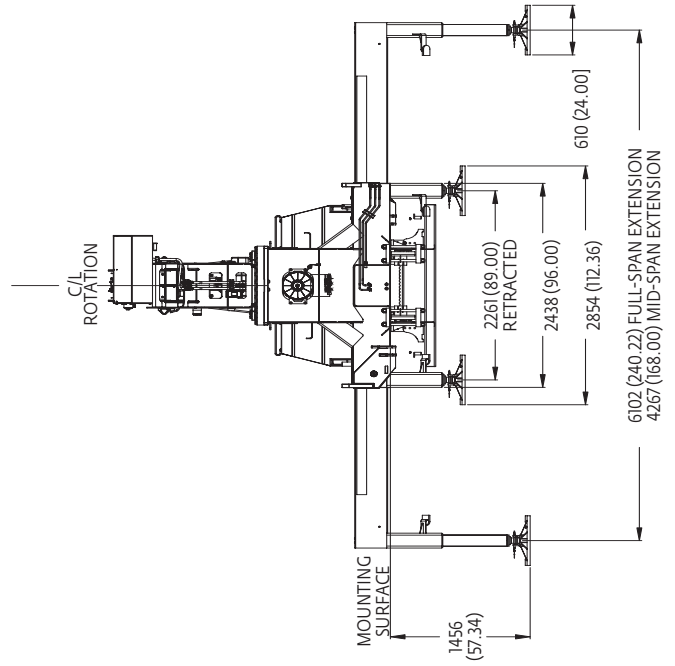

# Accessories

## **Radio Remote Control –**

Four-function radio remote control for standard unit and 6-function remotes with auger.

- NB6R

## **Steel Bulkhead**

- BHSD

## **Spanish-language Danger Decals, function control labels and Operators' Manuals**

- SDD
- SOM

## **Heavy-duty personnel basket –**

544 kg (1200 lb) capacity steel basket with safety loops for two passengers. Gravity leveling 183 cm x 107 cm (72 in x 42 in) platform. Fast attachment and secure locking systems. Load chart must show 1043 kg (2300 lb) minimum to operate this accessory.

- BSA-1
- BSA-R1 (provides rotation)
- BSAY-1
- BSAY-2

## **Winch drum Rotation Indicator**

- WDRI

## **Auger option 95 ft boom only**

14,000 ft-lb two speed auger. Maximum digging radius 39 ft (full outrigger and stabilizers only).

## **Oil Cooler**

Oil coolers recommended for duty cycle applications.

- OC

## **Hinged Vandal Cover Protector**

With keyed lock for LMI display.

- VCP

## Regional headquarters

### Manitowoc - Americas

**Manitowoc, Wisconsin, USA**

Tel: +1 920 684 6621

Fax: +1 920 683 6277

**Shady Grove, Pennsylvania, USA**

Tel: +1 717 597 8121

Fax: +1 717 597 4062

### Manitowoc - Europe, Middle East, Africa

**Ecully, France**

Tel: +33 (0)4 72 18 20 20

Fax: +33 (0)4 72 18 20 00

### Manitowoc - Asia Pacific

**Shanghai, China**

Tel: +86 21 6457 0066

Fax: +86 21 6457 4955

## Regional offices

### Americas

#### Brazil

Alphaville

#### Mexico

Monterrey

#### Chile

Santiago

### Europe, Middle East, Africa

#### Czech Republic

Netvorice

#### France

Baudemont

Cergy

Decines

#### Germany

Langenfeld

#### Hungary

Budapest

#### Italy

Lainate

#### Netherlands

Breda

#### Poland

Warsaw

### Portugal

Baltar

### Russia

Moscow

### U.A.E.

Dubai

### U.K.

Buckingham

### Asia - Pacific

#### Australia

Brisbane

Melbourne

Sydney

#### China

Beijing

Chengdu

Guangzhou

#### India

Delhi

Hyderabad

Pune

#### Korea

Seoul

#### Philippines

Makati City

#### Singapore

## Factories

### Brazil

Alphaville

### China

TaiAn

Zhangjiagang

### France

Charlieu

La Clayette

Moulins

### Germany

Wilhelmshaven

### India

Pune

### Italy

Niella Tanaro

### Portugal

Baltar

Fânzeres

### Slovakia

Saris

### USA

Manitowoc

Port Washington

Shady Grove

This document is non-contractual. Constant improvement and engineering progress make it necessary that we reserve the right to make specification, equipment, and price changes without notice. Illustrations shown may include optional equipment and accessories and may not include all standard equipment.